



# BC847AQ/BQ/CQ

## SOT-23 NPN Bipolar Transistor

## SOT-23 NPN 双极型三极管

### 1. Description 描述

This Bipolar Junction Transistor (BJT) is suitable for use in automotive applications.  
这种双极结晶体管 (BJT) 适用于汽车应用。

### 2. Features 特性

Feature 特性	Description 描述
Collector-Emitter Breakdown Voltage 集电极-发射极击穿电压	$BV_{CEO} > 45V$
Continuous Collector Current 连续集电极电流	$I_C = 0.1A$
Peak Pulse Current 峰值脉冲电流	$I_{CM} = 0.2A$
Applications 应用	For Switching and AF Amplifier 开关和 AF 放大器应用
Environmental Compliance 环保合规	Totally Lead-Free & Fully RoHS Compliant. 完全无铅和符合 RoHS 标准 <sup>[1]</sup> Halogen and Antimony Free, "Green" Device. 无卤素和无锑, "绿色"器件 <sup>[2]</sup>
Automotive Compliance 汽车合规	Qualified according to AEC-Q101 and recommended for use in automotive applications. 通过了 AEC-Q101 认证, 推荐用于汽车电子应用场景。

[1] No purposely added lead. Fully EU Directive 2002/95/EC (RoHS), 2011/65/EU (RoHS 2) & 2015/863/EU (RoHS 3) compliant.

无铅, 完全符合欧盟标准 2002/95/EC (RoHS), 2011/65/EU (RoHS 2) 和 2015/863/EU (RoHS 3)。

[2] Halogen- and Antimony-free "Green" products are defined as those which contain <900ppm bromine, <900ppm chlorine (<1500ppm total Br + Cl) and <1000ppm antimony compounds.

无卤素和无锑的“绿色”产品指溴含量<900ppm, 氯含量<900ppm (溴+氯总含量<1500ppm) 和锑化合物含量<1000ppm。

### 3. Mechanical Data 封装数据

Feature 特性	Description 描述
Package 封装	SOT-23
Moisture Sensitivity Level 湿敏感度等级	J-STD-020 MSL1
Material 材料	Molded Plastic, "Green" Molding Compound; UL Flammability Classification Rating 94V-0. 模塑塑料封装, "绿色" 成型复合材料; UL 可燃性等级 94V-0.
Dimensions 尺寸	1.9mm pitch; 2.9mm × 1.3mm × 1.0mm body 相邻引脚中心距为 1.9mm, 封装本体 (不含引脚) 尺寸为 2.9mm × 1.3mm × 1.0mm
Terminals Compliance 引脚合规	3 terminals, Tin Plated Leads, Solderable per MILSTD-202, Method 208 <sup>Ⓔ</sup> 3 个镀锡引脚, 可焊性符合 MIL-STD-202 标准中 208 方法 e3 条款的要求
Weight 重量	0.008 grams (Approximate) 约 0.008 克
Polarity 极性	See Diagrams Below 极性见下图

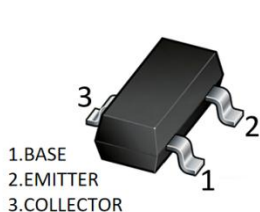

SOT-23 Top View

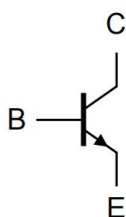

Device Symbol

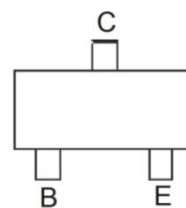

Top View Pin-Out

### 4. Ordering Information 订购信息

Part Number	Compliance	Package	Reel Size (inches)	Tape Width (mm)	Quantity Per Reel
BC847AQ	Automotive	SOT-23	7	8	3000
BC847BQ	Automotive	SOT-23	7	8	3000
BC847CQ	Automotive	SOT-23	7	8	3000

### 5. Marking Information 丝印信息

Part Number	Marking Code
BC847AQ	1E
BC847BQ	1F
BC847CQ	1G



## 6. Absolute Maximum Ratings( $T_a = + 25^{\circ}\text{C}$ ) 绝对最大额定值

Characteristic 特性	Symbol 符号	Value 值	Unit 单位
Collector-Base Voltage 集电极-基极电压	$V_{CBO}$	50	V
Collector-Emitter Voltage 集电极-发射极电压	$V_{CEO}$	45	V
Emitter-Base Voltage 发射极-基极电压	$V_{EBO}$	6	V
Collector Current 集电极电流	$I_C$	0.1	A
Peak Pulse Collector Current(single pulse) 峰值脉冲集电极电流 (单脉冲)	$I_{CM}$	0.2	A
Peak Pulse Emitter Current(single pulse) 峰值脉冲基极电流 (单脉冲)	$I_{EM}$	0.2	A

## 7. Thermal Characteristics( $T_a = + 25^{\circ}\text{C}$ ) 热特性

Characteristic 特性	Symbol 符号	Value 值	Unit 单位
Collector Power Dissipation 集电极耗散功率	$P_C$	200	mW
Thermal Resistance From Junction To Ambient 结到环境的热阻	$R_{\theta JA}$	625	$^{\circ}\text{C}/\text{W}$
Junction Temperature 结温	$T_J$	-55 ~ +150	$^{\circ}\text{C}$
Storage Temperature 储藏温度	$T_{stg}$	-55 ~ +150	$^{\circ}\text{C}$

## 8. ESD Ratings ESD 评级

Characteristic 特性	JEDEC Class JEDEC 等级	Value 值	Unit 单位
Electrostatic Discharge-Human Body Model (ESD HBM) 人体放电模型	3A	4000	V
Electrostatic Discharge-Machine Model (ESD MM) 带电器件模型	C	400	V

9. Electrical Characteristics( $T_a = +25^\circ\text{C}$ ) 电特性

Characteristic 特性		Symbol 符号	Min. 最小值	Typ. 典型值	Max. 最大值	Unit 单位	Conditions 条件
Collector-Base Breakdown Voltage 集电极-基极击穿电压		$BV_{CBO}$	50	-	-	V	$I_C = 10\mu\text{A}, I_E = 0$
Collector-Emitter Breakdown Voltage 集电极-发射极击穿电压 <sup>[3]</sup>		$BV_{CEO}$	45	-	-	V	$I_C = 10\text{mA}, I_B = 0$
Emitter-Base Breakdown Voltage 发射极-基极击穿电压		$BV_{EBO}$	6	-	-	V	$I_E = 1\mu\text{A}, I_C = 0$
Collector Cutoff Current 集电极截止电流		$I_{CBO}$	-	-	15	nA	$V_{CB} = 30\text{V}$
			-	-	100	nA	$V_{CB} = 50\text{V}$
Collector-Emitter Cut-Off Current 集电极-发射极漏电流		$I_{CES}$	-	-	15	nA	$V_{CE} = 50\text{V}$
Emitter-Base Cut-Off Current 发射极-基极漏电流		$I_{EBO}$	-	-	100	nA	$V_{EB} = 5\text{V}$
DC Current Gain 直流电流增益 <sup>[3]</sup>	BC847AQ	$h_{FE}$	110	180	220	-	$V_{CE} = 5\text{V},$ $I_C = 2\text{mA}$
	BC847BQ		200	290	450		
	BC847CQ		420	520	800		
Collector-Emitter Saturation Voltage 集电极-发射极饱和压降 <sup>[3]</sup>		$V_{CE(sat)}$	-	-	0.25	V	$I_C = 10\text{mA},$ $I_B = 0.5\text{mA}$
			-	-	0.5	V	$I_C = 100\text{mA},$ $I_B = 5\text{mA}$
Base-Emitter Saturation Voltage 基极-发射极饱和电压 <sup>[3]</sup>		$V_{BE(sat)}$	-	-	1.1	V	$I_C = 100\text{mA},$ $I_B = 5\text{mA}$
Transition Frequency 特征频率		$f_T$	100	-	-	MHz	$V_{CE} = 5\text{V}, I_C = 10\text{mA}$
Out Capacitance 输出电容		$C_{ob}$	-	4.5	-	pF	$V_{CB} = 10\text{V}, I_E = 0,$ $f = 1\text{MHz}$

[3] pulsed;  $t_p \leq 300\mu\text{s}$ ;  $\delta \leq 0.02$ . 测量时脉冲宽度 $\leq 300\mu\text{s}$ , 占空比 $\leq 0.02$ 。



## 10. Typical Electrical Characteristics Curve 典型电特性曲线

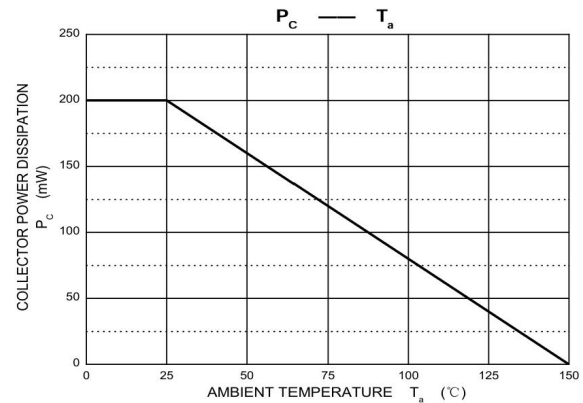
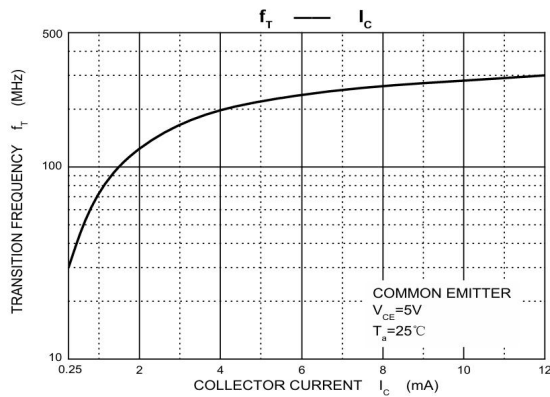
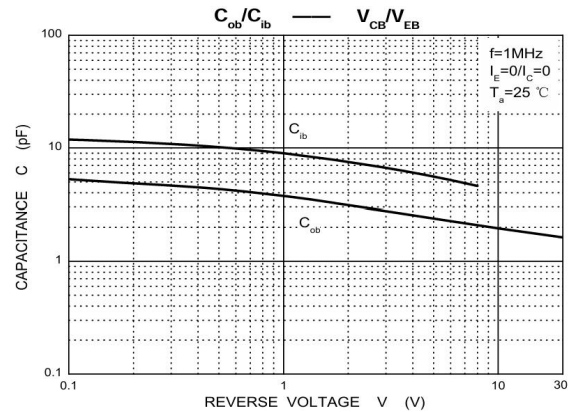
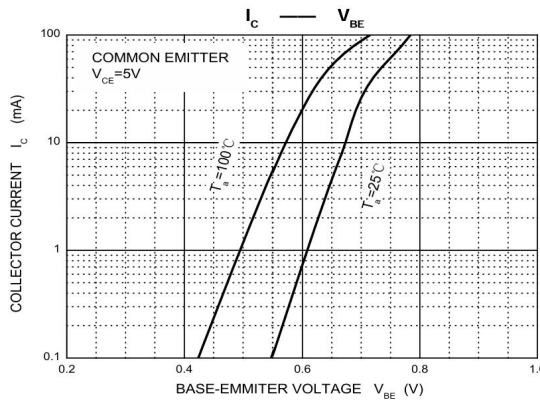
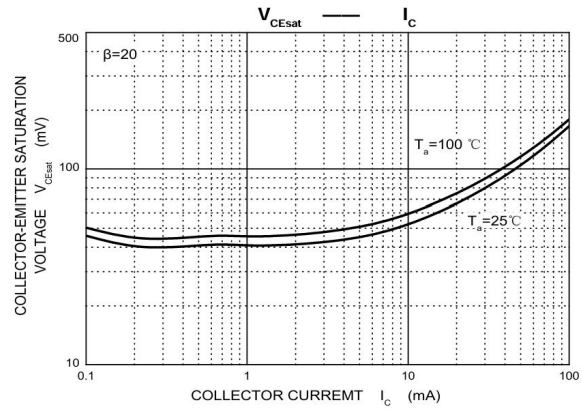
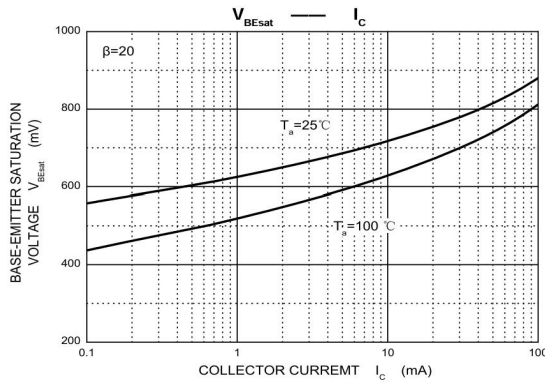
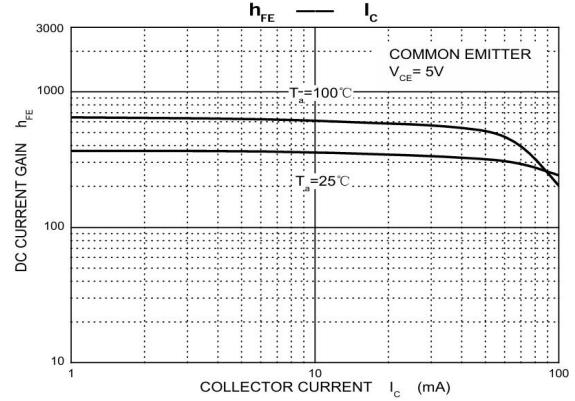
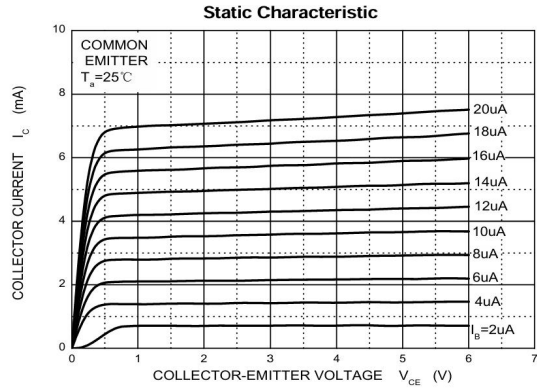

## 11. Package Outline Dimensions 封装外形尺寸

### SOT-23

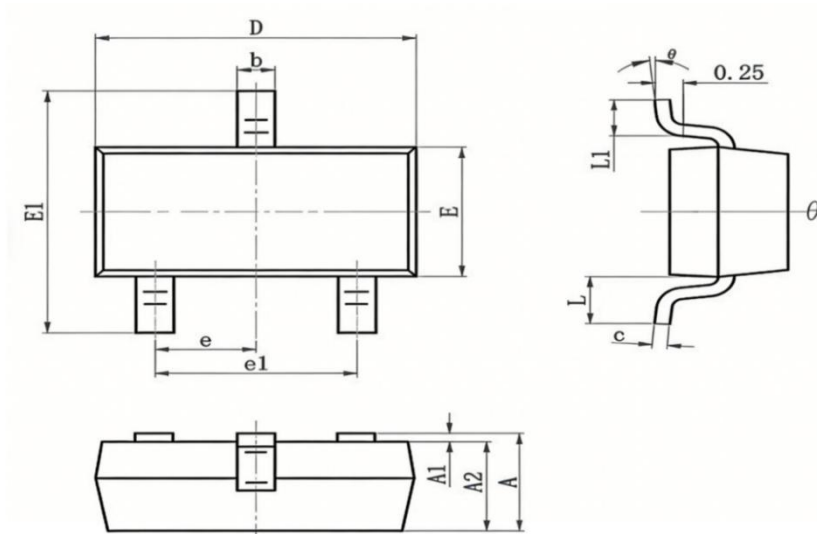

Symbol 符号	Millimeters 毫米	
	Min.最小值	Max.最大值
A	0.900	1.150
A1	0	0.100
A2	0.900	1.050
b	0.300	0.500
c	0.080	0.150
D	2.800	3.000
E	1.200	1.400
E1	2.250	2.550
e	0.900	1.000
e1	1.800	2.000
L	0.500	0.600
L1	0.300	0.500
$\theta$	0°	8°

## 12. Suggested Pad Layout 推荐焊盘布局

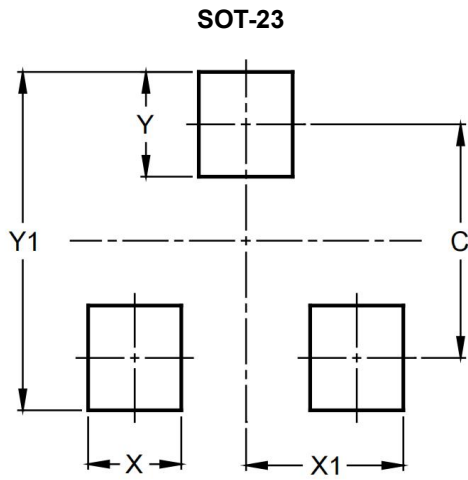

Dimensions 尺寸	Millimeters 毫米
C	2.0
X	0.8
X1	1.35
Y	0.9
Y1	2.9

Fig. Soldering footprint for SOT-23

图 SOT-23 的引脚焊接



### Important Notice 重要通知

Jingpeng Hulian( 'JPHL' ) company make no warranty of any kind,express or implied,with regards to any information contained in this document.Including,but not limited to, the implied warranties of the accuracy, completeness, merchantability, or non-infringement of third party intellectual property rights.

京鹏沪连公司(以下简称“JPHL”)对本文件包含的所有信息不提供任何明示或默认的担保,包括但不限于关于信息的准确性、完整性、适销性,以及不侵犯第三方知识产权的默认保证。

The Information contained herein is for informational purpose only and is provided only to illustrate the operation of JPHL products described herein and application examples. JPHL does not assume any liability arising out of the application or use of this document or any product described herein.

本文件内容仅作信息参考,仅用于说明文中所述 JPHL 产品的操作方法及应用示例。JPHL 不承担因应用或使用本文件或本文件中描述的任何产品而产生的任何责任。

JPHL reserves the right to make changes to information published in this document, at any time and without notice. This document supersedes and replaces all information supplied prior to the publication hereof.

JPHL 保留随时修改本文件已发布信息权利,且不另行通知,本文件将取代并替换其发布前提供的所有相关信息。

All referenced brands, product names, service names and trademarks are the property of their respective owners.

本文提及的所有品牌、产品名称、服务名称和商标,均归属其各自所有者。



## Contents 目录

1. Description 描述.....	1
2. Features 特性.....	1
3. Mechanical Data 封装数据.....	2
4. Ordering Information 订购信息.....	2
5. Marking Information 丝印信息.....	2
6. Absolute Maximum Ratings( $T_a = + 25^{\circ}\text{C}$ ) 绝对最大额定值.....	3
7. Thermal Characteristics( $T_a = + 25^{\circ}\text{C}$ ) 热特性.....	3
8. ESD Ratings ESD 评级.....	3
9. Electrical Characteristics( $T_a = + 25^{\circ}\text{C}$ ) 电特性.....	4
10. Typical Electrical Characteristics Curve 典型电特性曲线.....	5
11. Package Outline Dimensions 封装外形尺寸.....	6
12. Suggested Pad Layout 推荐焊盘布局.....	7
Important Notice 重要通知.....	8

---

© JPHL. 2025. All rights reserved

For more information, please visit: [www.jphl-semi.com](http://www.jphl-semi.com)

For business cooperation, please send an email to: [sales@jphl-semi.com](mailto:sales@jphl-semi.com)

Date of release: 26 Dec 2025

©京鹏沪连. 2025. 版权所有

想了解更多信息, 请访问 [www.jphl-semi.com](http://www.jphl-semi.com)

商务合作请发送电子邮件至 [sales@jphl-semi.com](mailto:sales@jphl-semi.com)

发布日期: 2025-12-26

---